

THE CLAIRCONNECT SWIMO

IS THE MOST RELEVANT CONTROLLER TO MANAGE WATER
QUALITY AND EQUIPEMENTS.

**MORE THAN 12 SENSORS AND 15 EQUIPEMENTS
WITH ONLY ONE BOX...**

A FULL HTTP API, AND MODBUS RTU STANDARD

A POWERFULL REGULATION CHOICE , A DEDICATED APP TO
DRIVE YOUR POOL OVER THE WEB OR ON YOUR LOCAL
NETWORK IN REAL TIME.

2 apps available IOS/ANDROID/WEBAPP

CLAIRCONNECT (Wood colors)

SWIMO (blue colors)

AN OPEN API FOR A FULL PROCESS AUTOMATION

LIFEDOMUS/ JEEDOM PLUGIN

ANY AUTOMATION PLATFORM WITH HTTP REQUESTS

PRE REQUIRED	- 5 -
1 - THE BOX	- 6 -
2 - THE RELAYS:	- 8 -
3 -THE ANALYSIS:	- 9 -
4- DRIVING:	- 10 -
5 -THE REGULATION TOOLS:	- 11 -
6 -CONNECT SENSORS	- 15 -
7 - CONNECT THE EQUIPMENT	- 17 -
8 - CONNECT TO THE NETWORK.	- 21 -
9 - DECLARE YOUR EQUIPMENT ON THE APPLICATION	- 24 -
10 - CALIBRATION:	- 25 -
FAQ	- 27 -
API LOCALE V2	- 28 -
GET ALL	- 30 -
UPDATE SYST	- 32 -
GET DEVICES	- 33 -
UPDATE DEVICE	- 33 -
GET ANALYSE	- 35 -
UPDATE SENSOR	- 37 -
ADD SENSOR	39
DEL SENSOR	39
ADD DEVICE	41
DEL DEVICE	41
ADD PLAGE	43
DEL PLAGE	44

CALIBRATION LINUX	45
SETUP WIFI LINUX	48
SET WIFI	49
RESET WIFI	49

PRE REQUIRED

ABOVE ALL, THE CONTROLLER IS A CONNECTED SYSTEM, WHOSE PRIMARY INTEREST IS REMOTE CONTROL AND MONITORING OF DATA.

YOU MUST ENSURE THAT YOUR CLIENT'S WIFI NETWORK IS REACHABLE AT THE LOCATION WHERE YOU ARE INSTALLING THE CONTROLLER.

IF NOT, ADD 2 POWER LINE BPL TERMINALS, PREFERABLY WIFI + ETHERNET, WHICH WILL ALLOW YOUR CLIENT TO CONNECT WITH HIS SMARTPHONE ON THE WIFI NETWORK BY BEING IN THIS ZONE AND ETHERNET TO SIMPLIFY THE CONNECTION WITH A CABLE BETWEEN THE CPL AND THE CONTROLLER.

OTHER SOLUTIONS, BY PULLING AN ETHERNET CABLE, OR BY ADDING A 3G BOX (WITH SUBSCRIPTION) ON A WIFI REPEATER (ALWAYS IN ORDER TO SIMPLIFY THE CONNECTION OF THE CONTROLLER AND THE CLIENT)

MAKE SURE THE POOL IS PROTECTED WITH GOOD QUALITY GROUND AND A POOL GROUND INSTALLED BEFORE THE PUMP (FILTRATION).

TIPS: KEEP A BOX OF 2 POWERLINE BPL, A REPEATER AND A 3G TERMINAL IN STOCK, A 1 OR 2 METER ETHERNET CABLE, A TECHNICAL LOCAL WALL SOCKET, THE ELECTRICAL CABLE 3 X 1.5 MM² AND 3 X 2.5 MM²,

THE THREADED JOINT, SUPPORT COLLARS
AT THE BASIN DIAMETER 50 OR 63 IN ½
INCH, 3/8 OR 10 MM PIPE.

1 – THE BOX



TECHNICAL SHEET :

SWIMO PRO (ROHS, CE STANDARDS)

LAUNCHED : III - 04/2018

PH BNC - DC + -5 V VOLTAGE SIGNAL

3-10 PT RANGE - 2-POINT LINEAR
CALIBRATION

ORP / REDOX BNC - DC + -5 V
VOLTAGE SIGNAL

RANGE 0 TO 1200 mV - 2-POINT LINEAR
CALIBRATION

EC (CONDUCTIVITY) BNC-AC VOLTAGE
SIGNAL + -5 V

0 TO 20 MS / CM / 0 TO 10000 PPM - NON-
LINEAR 3-POINT CALIBRATION

TEMPERATURE LINEARIZED VOLTAGE
SIGNAL DC + -5 V

RANGE -20 TO 60 ° C - PT100 - 4

NONLINEAR CALIBRATION POINTS (ADMIN)

DETECTORS 6 ON / OFF CONTACTS
(TOR)

ACTUATORS 15 ACTUATORS FOR 12V
COIL.

MICRO PROCESSOR Opos6UL - 560
MHZ - EMMC 4 GB

WIFI (B, G, N) - BLUETOOTH (LOW
ENERGY)

POWER SUPPLY 12 VOLT - 2000 MA

OPERATION - 20 ° C TO 70 °

PORTS: 100 Gb / s ETHERNET, USB A -
USB OTG

ANALOG SIGNALS SUPP: 2 INPUTS 4-
20 mA - 12V - 250 mA

WATER LEVELS, PRESSURE SENSOR ...

MODBUS RS485 / MODBUS INPUT, 12V /
GND / RX + / RX-

AMPEROMETRIC CHLORINE PROBE,
TURBIDITY SENSOR, PRESSURE SENSOR ...

IP55 BOX, INDOOR / OUTDOOR
INSTALLATION UNDER ROOF.

SOM DEVELOPED AND MANUFACTURED IN
FRANCE. MOTHERBOARD DEVELOPED AND
MANUFACTURED IN FRANCE. BOX MOLDED
AND MADE IN FRANCE.

2 - THE RELAYS:

USE RELAYS WITH COIL OR 12V SIGNAL.

EITHER DIN RAIL RELAYS, KNX RELAYS
OR 1 TO 2 DEDICATED RELAY BOXES



THE RELAY ACTS AS A SWITCH. SO WE
WILL INSTALL FOR EXAMPLE THE BROWN
WIRE COMING FROM THE ELECTRICAL
SUPPLY BOX ON THE COM PORT AND THE
BROWN WIRE OF THE DEVICE TO BE
PILOTED ON THE PORT NO, WHILE THE
NEUTRAL WIRES WILL BE CONNECTED LIVE
ON A DOMINO FOR EXAMPLE.

IN THE CASE NO, IF WE ACTIVATE THE
RELAY, THE CURRENT PASSES, OTHERWISE
IT DOES NOT PASS

IN THE CASE NC, THE CURRENT PASSES,
ONCE ACTIVATES THE RELAY THE CURRENT
DOES NOT PASS.

(BY DEFAULT THE CONTROLLER WORKS IN
NO MODE, BUT IT CAN BE CHANGED
DEPENDING ON THE DEVICES YOU

CONNECT AND THE WAY YOU WANT TO
MANAGE THE FUNCTIONS.

SEE IN THE ADMIN PAGE, AT FIRST BOOT,
ON SWIMO-XXXX NETWORK

[HTTP://192.168.240.1](http://192.168.240.1) OR WHEN THE
CONTROLLER IS CONNECTED TO THE LOCAL
NETWORK, CHECK IP ON YOUR ADMIN
WEBPAGE [HTTPS://AUTOMATION.AC](https://automation.ac) OR
YOUR LOCAL INTERNET SUPPLIER BOX
ADMIN PAGE.

3 -THE ANALYSIS:

THE CONTROLLER IS USUALLY SUPPLIED WITH 5 ANALOG PROBES

PORT N ° 1 - BNC PH PROBE

PORT N ° 2 - BNC REDOX / ORP PROBE

PORT # 3 - BNC CONDUCTIVITY / EC PROBE

PORT N ° 4 - TEMPERATURE PT100 - THE RED ON THE LEFT, THE OTHER ONE OR THE TWO OTHERS ON THE RIGHT

PORT N ° 7 - THE FLOW ON THE FIRST 2 INSERTS OF THE CONNECTOR OF 12 INSERTS (ONE CAN HOWEVER CHOOSE BETWEEN THE PORTS 7 TO 12.)

OTHER PORTS

N ° 13 - THE AMPEROMETRIC CHLORINE PROBE CONNECTS ON THE RS485 PORT WITH 4 INSERTS (BLACK, GREEN, WHITE AND RED) FROM LEFT TO RIGHT - COMPENSATED READING ACCORDING TO PH AND TEMPERATURE TO DISPLAY THE FREE ACTIVE CHLORINE IN MG / L

(OUR MODEL CC5530)

N ° 18 - HUMISTEAM CAREL GENERATOR ON THE RS485 PORT WITH 4 INSERTS (BLACK, +, -) FROM LEFT TO RIGHT.

(see CAREL suppliers)

4-20 MA PORTS

N ° 5 AND 6 - PRESSURE PROBE, TEMPERATURE PROBE FOR SAUNA, AND SOME OTHERS...

DETECTORS (ALL-OR-NOTHING CONTACTS)

PORTS N ° 7 TO 12 - END OF BOTTLE DETECTOR, SWITCH DETECTOR FOR HAMMAM DOOR, HIGH AND LOW LEVEL DETECTOR FOR BUFFER TANK, SHUTTER CLOSED SHUTTER AND ELECTROLYSIS DETECTOR.

DEVELOPMENT NOTE :

4-20 mA and RS485 port are ready to connect DO, TURBIDITY or Others PH an ORP probe or connect any modbus equipement that your need in near future.

Just contact our team developper to get your code ready to work with your equipement

Send an email with your technical modbus sensors /devices datas

To : fred.lemaitre@iotflowers.com

4- DRIVING:

WE HAVE 4 SECURITIES PROCESS TO ALLOW OR NOT A DEVICE TO BE DRIVE OR HOW IT CAN BE DRIVE FROM OVER THE WEB AND IN LOCAL AREA

SECURITY 0

BY DEFAULT ALL UNREGULATED DEVICES HAVE 3 OPERATING MODES

ON / OFF AND AUTO

AUTO CREATES 8 TRACKS PER DAY AND PER EQUIPMENT: A WEEKLY DIGITAL CLOCK FOR ALL EQUIPMENT.

SECURITY 3

SENSITIVE DEVICES:

SHUTTER, REELS, COVER, REQUIRE 2 RELAYS FOR OPENING AND CLOSING AND OPERATES IN THE FORM OF A PUSH BUTTON. WE MUST STAY IN SUPPORT FOR THE ACTION TO CONTINUE. THIS TYPE OF DEVICE CAN NOT BE CONTROLLED OUTSIDE THE CUSTOMER'S LOCAL NETWORK.

SECURITY 2

THE DOSING PUMPS ARE GENERALLY WITH THE PUSH MODE IN ON MODE, BUT ACCORDING TO THE NEEDS, THEY CAN GO INTO SAFETY MODE 1

SECURITY 1

PRESSING THE ON BUTTON WILL INITIATE A 30-SECOND SEQUENCE, THEN THE BUTTON WILL RETURN TO OFF.

5 -THE REGULATION TOOLS:

BY DEFAULT AN ALERT IS SENT BY EMAIL AND LOCAL NOTIFICATION ON THE APPLICATION AS SOON AS A MINIMUM OR MAXIMUM ALARM IS REACHED. IN GENERAL, THESE ALARMS ARE ABLE TO TURN OFF THE CONTROL EQUIPMENT CONCERNED. AS LONG AS AN ALARM IS NOT DELETED, NO OTHER ALARM OF THE SAME TYPE CAN BE SENT. THE MANAGEMENT OF THE ALARMS IS NOT SUBJECT TO APPROVAL, THE SYSTEM WILL SYSTEMATICALLY SEND A NOTIFICATION AS SOON AS AN ALARM IS REACHED. THE CONTROLLER IS ABLE TO MANAGE TOGETHER ALL THE EQUIPMENT OF THE TECHNICAL ROOM ACCORDING TO THE CONNECTED DEVICES.

ALL EQUIPMENTS HAVE TIME SLOTS MODE.

HEATING:

THE ON MODE REMAINS LIT WITHOUT LIMIT, AS LONG AS THE FILTRATION IS ON, AND TURNS OFF IF THE MAX ALARM IS REACHED (40 ° C BY DEFAULT - CHANGEABLE -)

AUTO MODE IS COMPOSED OF 2 SUB MODE MAX AND ECO

ECO, ONCE THE SET POINT REACHES, THE HEATING RESTARTS AT 2 ° C BELOW THE SETPOINT

MAX, ONCE THE SET POINT IS REACHED, THE HEATING STARTS AGAIN AT 1 ° C BELOW THE SET POINT, AND THE HEATING

STARTS THE PUMP FILTRATION IF NECESSARY, EVEN OUT OF RANGE.

PH- AND / OR PH + PUMP:

THE ON MODE REMAINS LIT IN PRESSURE OR 30 SECONDS DEPENDING ON THE SELECTED SECURITY CODE

AUTO MODE HAS 2 SUB MODES MAX AND ECO

ECO: THE TOLERANCE IS 0.2 PT OF PH BEFORE THE PUMP GOES OFF

MAX: THE TOLERANCE IS 0.1 PT OF PH BEFORE THE PUMP IS TRIGGERED

IF BOTH PH + AND - PUMPS ARE INSTALLED, ONE CAN NOT WORK IF THE OTHER HAS BEEN RUNNING ON THE DAY.

THERE IS A MAXIMUM INJECTABLE DAILY, DEPENDING ON POOL VOLUME AND POWER DOSING PUMP. THE CONTROLLER CALCULATES THE CONSUMPTION OF CANS IN REAL TIME.

BY DEFAULT AN ALERT IS SENT AS SOON AS THE CAN IS LESS THAN 2 LITERS

REDOX PUMP: IT WORKS ACCORDING TO THE READING OF THE REDOX PROBE FOR CHLORINE OR ACTIVE OXYGEN.

THE ON MODE REMAINS LIT IN PRESSURE OR 30 SECONDS DEPENDING ON THE CHOSEN SECURITY CODE

AUTO MODE HAS 2 SUB MODES MAX AND ECO

ECO: THE TOLERANCE IS 30 mV BEFORE THE PUMP GOES OFF

MAX: THE TOLERANCE IS 15 mV BEFORE THE PUMP GOES OFF

THERE IS A MAXIMUM INJECTABLE DAILY, DEPENDING ON POOL VOLUME AND POWER DOSING PUMP. THE CONTROLLER CALCULATES THE CONSUMPTION OF CANS IN REAL TIME.

BY DEFAULT AN ALERT IS SENT AS SOON AS THE CAN IS LESS THAN 2 LITERS.

CHLORINE PUMP:

IT WORKS ACCORDING TO THE READING OF THE CHLORINE AMPERO PROBE FOR FREE CHLORINE.

THE ON MODE REMAINS LIT IN PRESSURE OR 30 SECONDS DEPENDING ON THE CHOSEN SECURITY CODE

AUTO MODE HAS 2 SUB MODES MAX AND ECO

ECO: THE TOLERANCE IS 0.2 MG / L BEFORE THE PUMP GOES OFF

MAX: THE TOLERANCE IS 0.1 MG / L BEFORE THE PUMP IS TRIGGERED

THERE IS A MAXIMUM INJECTABLE DAILY, DEPENDING ON POOL VOLUME AND POWER DOSING PUMP. THE CONTROLLER CALCULATES THE CONSUMPTION OF CANS IN REAL TIME.

BY DEFAULT AN ALERT IS SENT AS SOON AS THE CAN IS LESS THAN 2 LITERS.

ELECTROLYSIS

: IT WORKS ACCORDING TO THE READING OF THE REDOX PROBE, OR CHLORINE AMPERO FOR WITH THE CONDUCTIVITY PROBE IN SALINITY MODE

THE ON MODE REMAINS LIT AS LONG AS THE FILTRATION IS WORKING AND THE MAX ALARM IS NOT REACHED.

AUTO MODE HAS 2 SUB MODES MAX AND ECO

ECO: THE TOLERANCE IS 0.2 MG / L OR 30 mV BEFORE THE ELECTROLYSIS IS TRIGGERED

MAX: TOLERANCE IS 0.1 MG / L OR 15 mV BEFORE ELECTROLYSIS IS TRIGGERED

THERE IS A PERFORMANCE RATIO BETWEEN THE SALT LEVEL WHICH MUST BE BETWEEN 3 AND 5 G / L DEPENDING ON THE TEMPERATURE (THE HIGHER THE TEMPERATURE, THE LESS SALTS ARE NEEDED).

THUS BESIDES THE MANAGEMENT OF THE ELECTROLYSIS BY THE REDOX OR THE CHLORINE, THE SYSTEM TAKES INTO ACCOUNT THE RATE OF SALT TO

DETERMINE THE QUALITY OF THE
PRODUCTION OR POSSIBLY THE NON-
PRODUCTIVITY DUE TO A LACK OF SALTS.

FILTRATION:

4 MODES AVAILABLE, DAY, NIGHT, WINTER, SHOCK

ACCORDING TO THE POOL VOLUME, THE WATER TEMPERATURE, THE POWER OF THE PUMP.

DAY: 2 TIME SLOTS ARE GENERATED EACH DAY ACCORDING TO THE AVERAGE TEMPERATURE OF THE DAY BEFORE. ONE BEFORE NOON, THE OTHER AFTER 2 PM

NIGHT: 2 TIME SLOTS ARE GENERATED EACH NIGHT ACCORDING TO THE AVERAGE TEMPERATURE OF THE DAY BEFORE, ONE BEFORE MIDNIGHT, THE OTHER AFTER 3 AM

WINTER: 4 TIME SLOTS OF 30 MINUTES, EVERY 6 HOURS WHICH PASSES FORCED FILTRATION TO ON WHEN THE WEATHER RETURNS 4 ° C OR LESS, OR THE WATER IS BEHIND 2 ° C WITH OR WITHOUT HEATING MANAGEMENT (IF IT IS AUTO OR OFF) WITH ALARM MANAGEMENT IF, DESPITE THIS, THE TEMPERATURE CONTINUES TO FALL AND THE FREEZE MUST SETTLE.

SHOCK: FOR A SUCCESSFUL RESTART, THE FILTRATION WILL BE ORGANIZED WITH THE DIFFERENT TREATMENT EQUIPMENT OVER A PERIOD OF 48 HOURS.

MULTICOLOUR LED RTC

The RC protocol is implemented with 18 speeds level, for 8 plain colours and 11 sequences, with a simple relay.

MULTICOLOUR LED RTC

The RC protocol is implemented with 18 speeds level, for 8 plain colours and 11 sequences, with a simple relay.

6 –CONNECT SENSORS

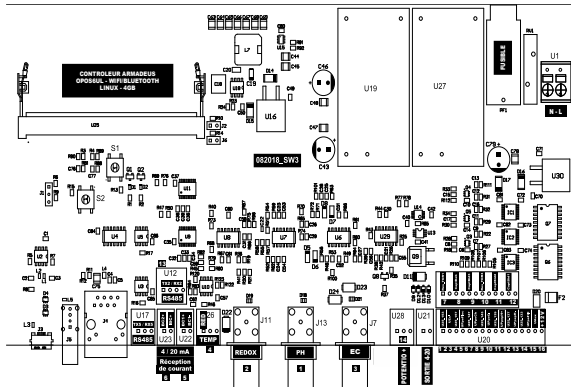

- 1 – PH PROBE WITH A BIG BULB
- 1 – ORP PROBE WITH A SMALL BULB AND AN CENTRAL ELECTRODE
- 3 - THE EC PROBE, 2 PLATINUM ELECTRODES WITHOUT BULB.

MOUNT THE ANALYSIS CHAMBER AND INSTALL THE 2 SUPPORT COLLARS IDEALLY BEFORE AND AFTER THE FILTER TO GENERATE PRESSURE TO THE CHAMBER.

TURN ON THE PUMP, VALVES CLOSED AND OPEN THEM GENTLY TO CHECK FOR LEAKS. POSSIBLY, TIGHTEN, REJOIN, WELL EMBED THE WHITE TUBES IN THE QUICK CONNECTS.

HYDRAULIC INSTALLATION

THE DEPORTED ROOM

THE SWIMO KIT COMES WITH AN ANALYSIS CHAMBER TO SUPPORT 3 PROBES OF 12 MM DIAMETER, 1 INPUT AND 1 OUTPUT OF 3/8 " FOR THE FLOW SENSOR, 2 ADDITIONAL THREADS OF 3/8 " WITH PLUGS AND 1 D10 THREAD FOR PT100

TEMPERATURE SENSOR, 2 METERS 9.52MM HOSE, 2 ½ / QUICK VALVES 9.52.

THE CHAMBER IS DELIVERED WITH PROBE HOLDERS OR PLUGS ACCORDING TO THE NUMBER OF PROBES PROVIDED.

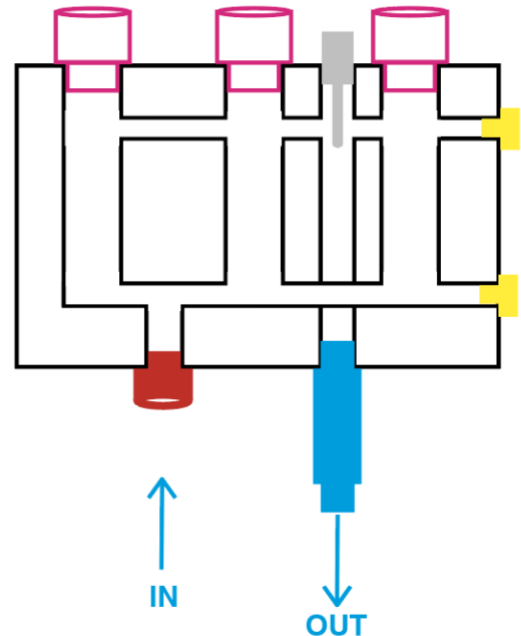

WHERE TO INSTALL IT

TO OBTAIN SUFFICIENT PRESSURE IN THE CHAMBER WITHOUT ADDING A VALVE TO YOUR EXISTING CIRCUIT, PLACE AN INLET AFTER THE FILTRATION PUMP (BEFORE THE FILTER) AND THE OUTLET AFTER THE FILTER WITH 2 SUPPORT CLAMPS WITH $\frac{1}{2}$ THREAD. THUMB.

NOTE: THIS INSTALLATION IS ECONOMICAL BUT POSES 2 PROBLEMS

RISK OF RADIATION FROM A LEAKAGE CURRENT OF THE PUMP, DISTURBING THE PROBES.

DIRT IN THE ACCELERATED CHAMBER (BEFORE FILTER)

THE OTHER METHOD IS TO PLACE A BYPASS WITH A VALVE ON THE CIRCUIT AFTER THE FILTER OR TAKE ADVANTAGE OF THE BYPASS OF THE HEAT PUMP. A SUPPORT COLLAR WILL BE PLACED ON EACH SIDE OF THE VALVE.

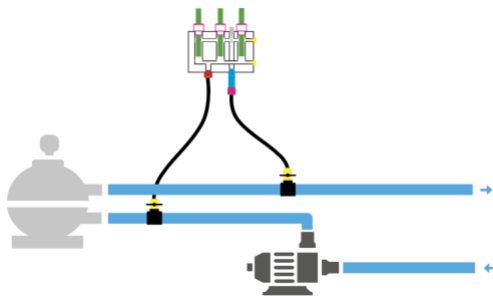
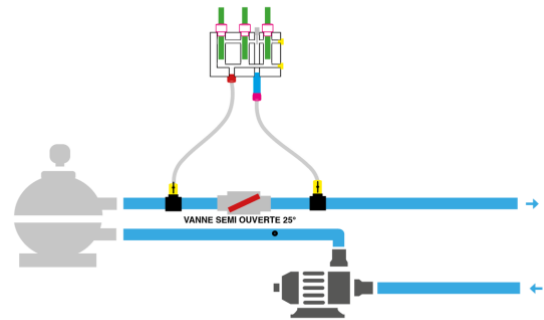

TO CONNECT THE ELECTRICAL PART, THERE ARE SEVERAL CASES:

ELECTRICAL INSTALLATION

FOR EQUIPMENT OVER 10 A, USE A POWER CONTACTOR SUITABLE FOR THE EQUIPMENT.

YOU CAN ALWAYS ADD 2 OR 3 POSITION BUTTONS TO KEEP MANUAL FUNCTIONS

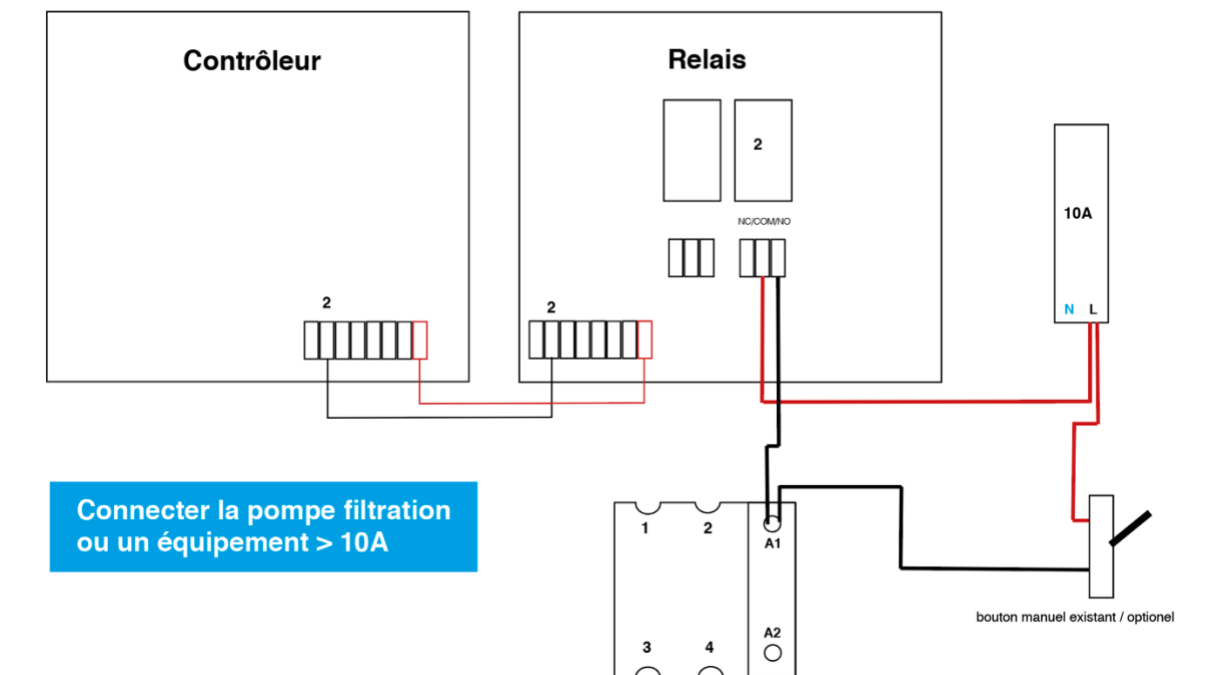

THE CONNECTION OF SMALL EQUIPMENT DOES NOT REQUIRE POWER.

YOU CAN FEED THE COM PORT OF A RELAY THEN MAKE BRIDGES BETWEEN SEVERAL COM TO BRING THE PHASE AND JOIN ALL THE NEUTRALS ON A DOMINO, THEN YOU CONNECT THE BROWN OF THE EQUIPMENT ON THE NO AND THE NEUTRAL ON THE DOMINO

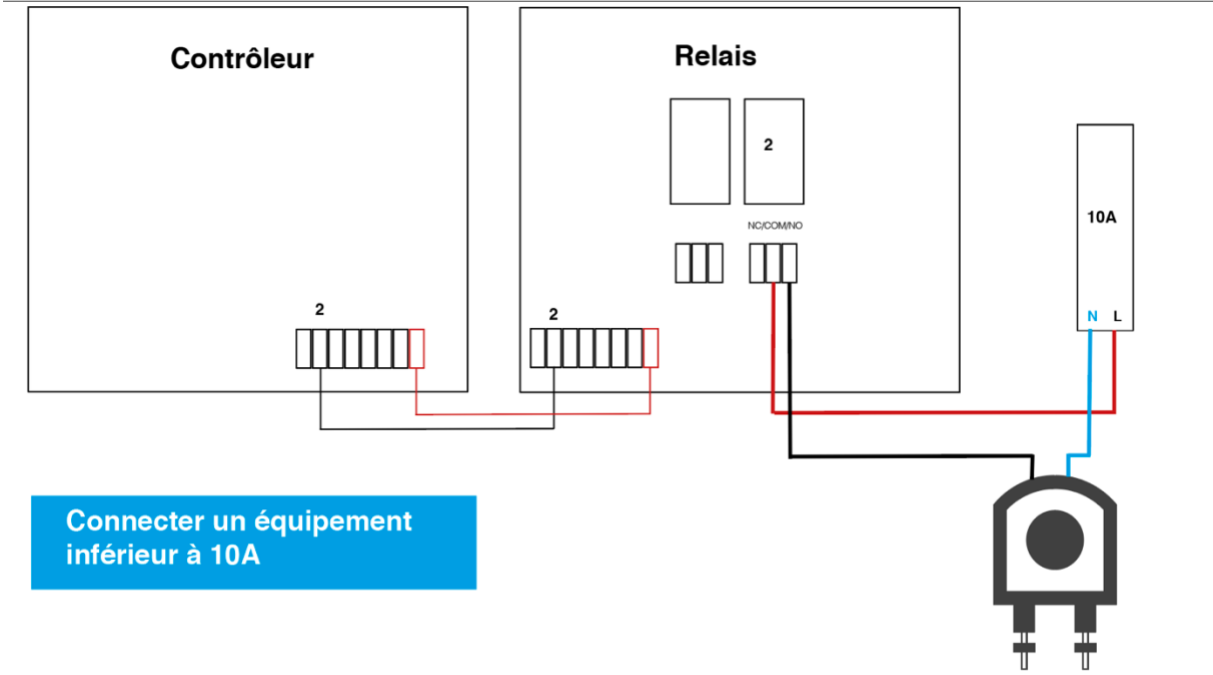

FOR SOME EQUIPMENT PUMPS, PAC, HEATING WITH A DRY CONTACT TYPE REMOTE CONTROL, YOU MAKE A RETURN TRIP BETWEEN THE COM / NO AND THIS CONTACT

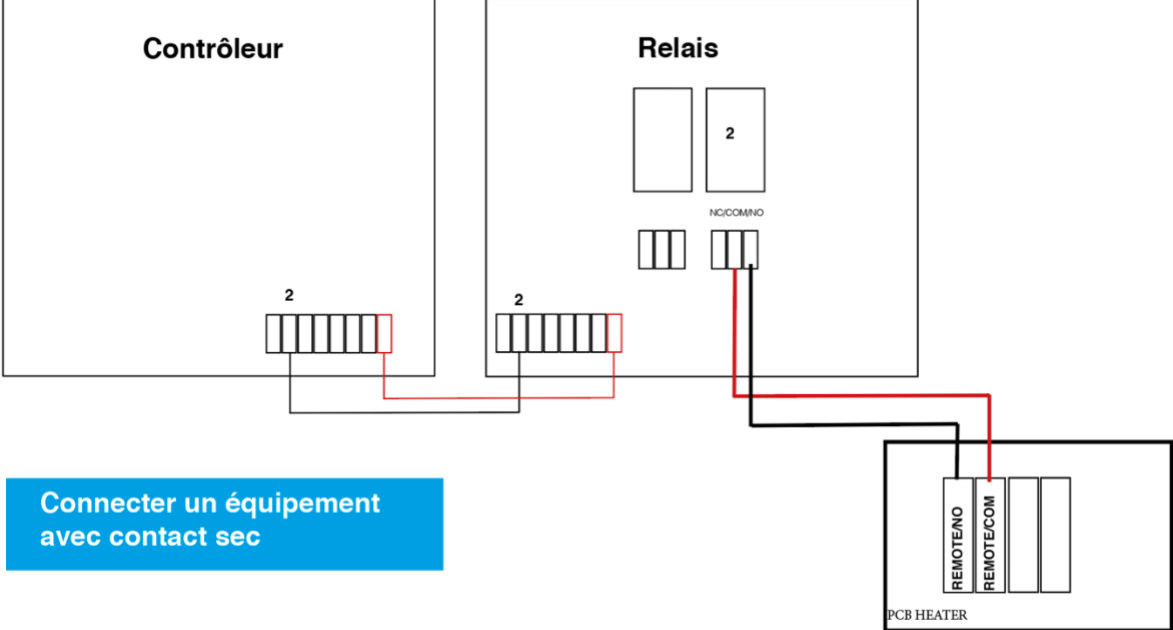

8 - CONNECT TO THE NETWORK.

YOU HAVE CONNECTED ALL YOUR DEVICES, ALL YOUR PROBES, YOU HAVE VERIFIED THAT THE WIFI NETWORK OF YOUR CLIENT IS CONSISTENT OR A CPL / ETHERNET IS AVAILABLE ... IT TIME TO CONNECT THE CONTROLLER TO THE NETWORK.

YOU TURN ON THE CONTROLLER, ALL THE RELAYS COME ON FOR 10 SECONDS, YOU TAKE THE OPPORTUNITY TO CHECK THAT ALL THE EQUIPMENT STARTS. (IF THIS MODE DOES NOT SUIT YOU, DISCONNECT THE 12V WIRE FROM THE ACTUATORS FOR THE TIME OF THE SYSTEM BOOT)

1 / ETHERNET: YOU PLUG THE CABLE, IT'S DONE.

2 / BY WIFI: YOU CONNECT WITH YOUR SMARTPHONE ON THE WIFI NETWORK NAMED :

SSID : SWIMO-XXXXXXX

PASSWORD : SWIMO000



(AS THIS NETWORK DOES NOT HAVE INTERNET ACCESS, YOUR SMARTPHONE CAN REJECT IT, INSIST 2 MORE TIMES !)

ONCE LOGGED IN, OPEN YOUR APP AND LOG IN WITH YOUR ACCOUNT OPENED ON THE CONSOLE

[HTTPS://AUTOMATION.AC/APP/LOGIN.PHP](https://automation.ac/app/login.php)

YOUR SERIAL NUMBER IS PASTED ON THE USER MANUAL, AND ON THE MICRO PROCESSOR IT SELF

YOU HAVE ENTERED ALL YOUR COORDINATES, INFORMED THE TYPE OF POOL, POSSIBLY YOU HAD PREPARED ALL THE SENSORS AND RELAY ... IT'S PERFECT.

ONCE THE CONTROLLER IS CONNECTED TO THE NETWORK, IT WILL SUCK ALL THAT DATA.

SO LOGIN / PASSWORD, YOU ARRIVE ON THE COVER PAGE, YOU CLICK ON THE TOP RIGHT TO SWITCH TO LOCAL MODE> YOUR SMARTPHONE CONNECTS TO THE CONTROLLER ON HIS NETWORK.

YOU ARE AN INSTALLER AND DO NOT KNOW THE CUSTOMER ACCOUNT YET.

ON THE LOGIN PAGE, CLICK ON THE TOP RIGHT TO SWITCH TO LOCAL MODE

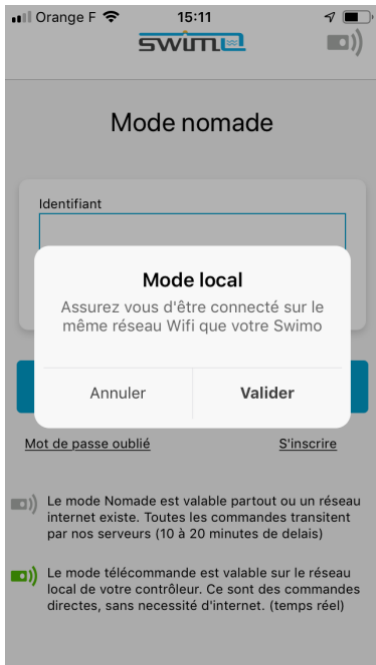

ENTER SERIAL NUMBER 1,

APIKEY 1 AND

IP 192.168.240.1 (YOU MUST BE CONNECTED TO THE SWIMO NETWORK)

YOU ARRIVE ON A BLANK PAGE (NORMAL, NOTHING IS SET).

YOU CLICK ON THE TOP LEFT AND THEN ON THE DEVICE SETTING

YOUR CLICK ON NETWORKS NEARBY, YOU SELECT THE ONE OF THE CLIENT

THEN YOU ENTER HIS PASSWORD WIFI (WITHOUT MAKING AN ERROR)

ON FIRST TAB, YOU MAY ENTER USER ACCOUNT AND SELECT LANGAGE.



9 - Declare your equipment on the application

On the device setup page, add your sensors and devices by scrupulously following the numbers. And validate at the top right after each choice.

Once this part is finished, enter each equipment to indicate its power, possibly the setpoint and the mode.

Check your account for the type of POOL and the POOL volume.

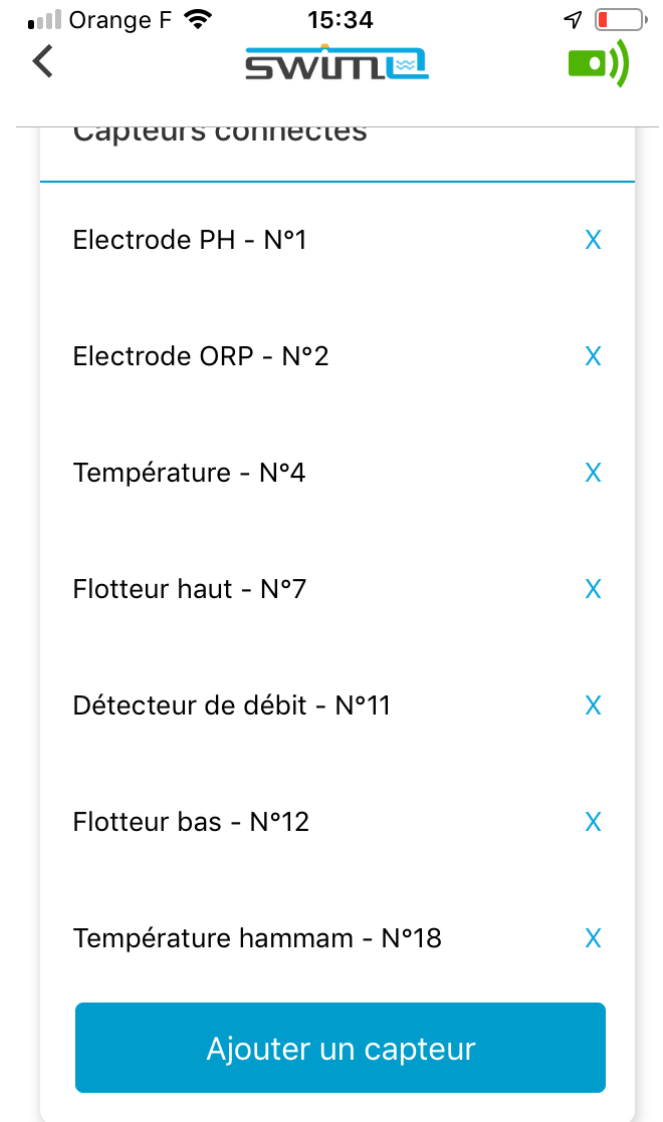
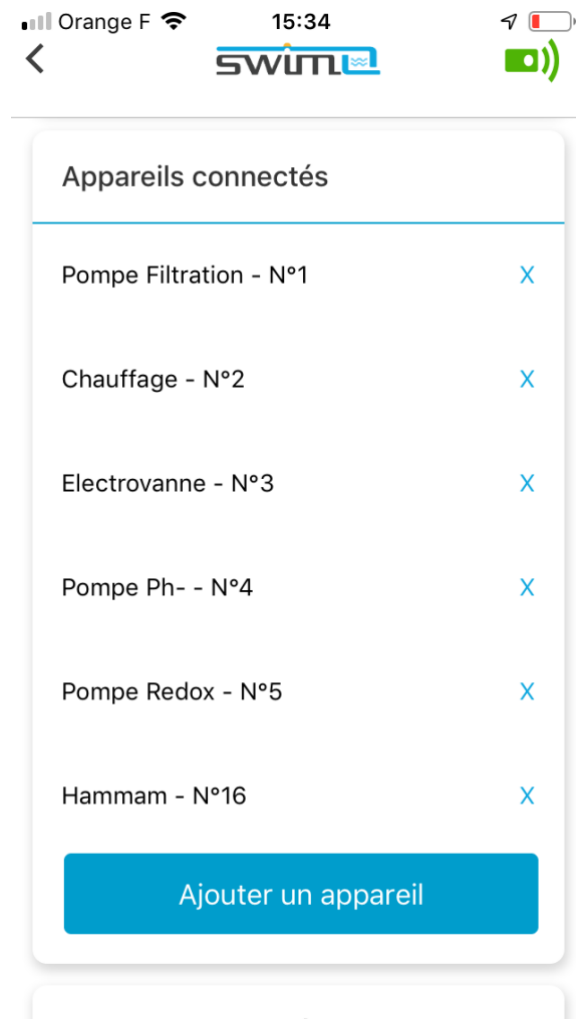

10 - CALIBRATION:

IT IS ESSENTIAL TO DO THE PH AND REDOX CALIBRATIONS TO ENSURE THAT THE PROBES GIVE AN ACCURATE READING.

IN LOCAL MODE, CLICK ON THE ORP / REDOX SENSOR TOOL ICON FOR EXAMPLE

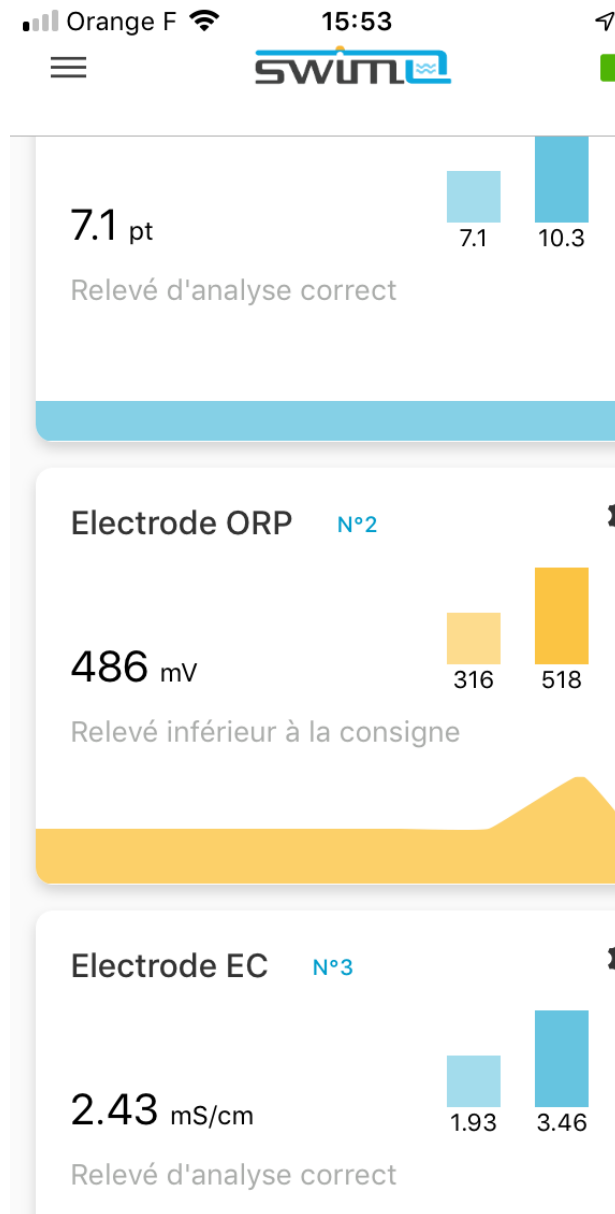

THEN CLICK ON CALIBRATION



ENTER THE 2 BATH VALUES

INSERT THE PROBE IN THE 1ST BATH

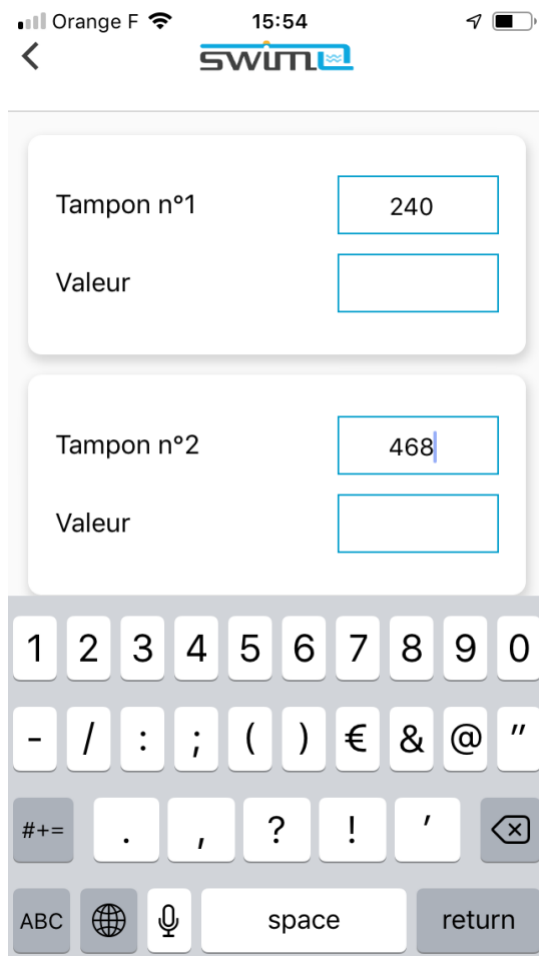

CLICK ON THE CIRCLE TO START AND FOLLOW THE INSTRUCTIONS

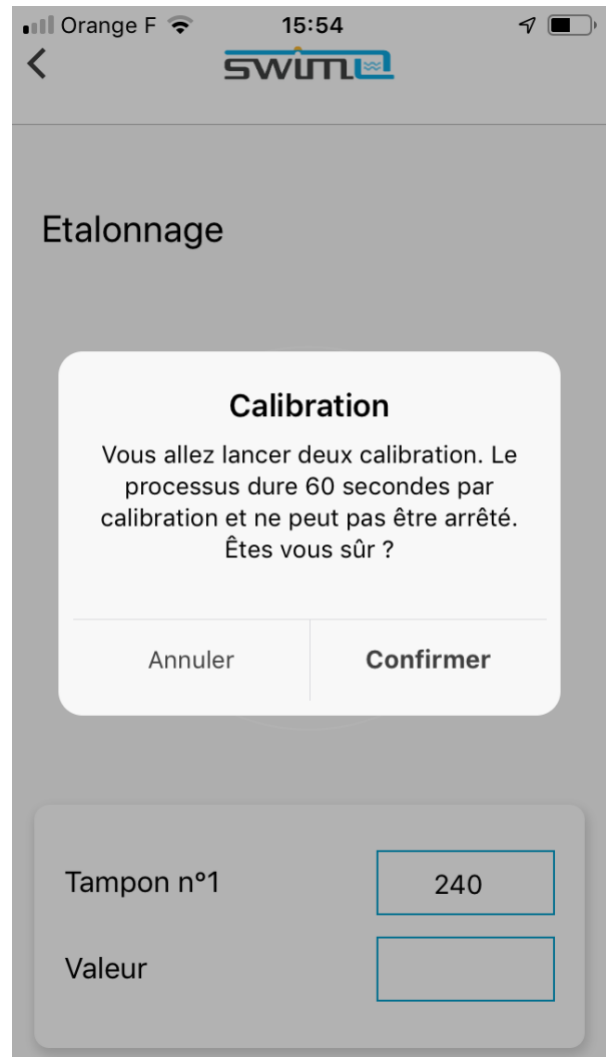

ONCE THE CALIBRATION IS FINISHED, YOU ARE SENT BACK TO THE DETAIL PAGE OF THIS SENSOR

FAQ

1 / DO YOU HAVE A FAULTY ANALOG SIGNAL?

THE PH INDICATES + OF 9, THE REDOX DROPS CLOSE TO 0?

THIS INDICATES A LEAKAGE CURRENT, IT CAN COME FROM THE PUMP FILTRATION IN GENERAL AND WILL BE CORRECTED WITH

- A POOL OF EARTH

BUT IT CAN ALSO COME FROM FAULTY PROBES

- DISCONNECT THE EC SENSOR > IF THE PH SIGNAL RISES, GOOD PICK

- DISCONNECT THE RED WIRE FROM THE TEMPERATURE SENSOR

- DISCONNECT THE GND FROM THE RS485 PORT

THE SOLUTION IS NOT THERE? CONTACT +336 80 24 60 92

2 / CONNECTED EQUIPMENT WILL NOT START?

MAKE SURE THAT IT IS NOT AN EQUIPMENT DEPENDENT ON FILTRATION

SWITCH ON THE FILTRATION AND MAKE SURE THAT THE FLOW SENSOR INDICATES 1

CHECK THE SIGNAL WIRE BETWEEN THE CONTROLLER AND THE RELAY, AND ITS NUMBER ON THE APPLICATION MUST MATCH THE NUMBER ON THE MOTHERBOARD.

THE PHASE ARRIVES ON COM, THE BROWN WIRE OF THE EQUIPMENT IS ON NO, THE BLUE WIRE IS ON A DOMINO WITH THE NEUTRAL

THE SOLUTION IS NOT THERE? CONTACT +336 80 24 60 92

3 / WIFI NETWORK IS NOT SET CORRECTLY ?

CLICK ON SWITCH WIFI BUTTON ON THE MAIN BOARD FOR 10 SECONDS AND WAIT TO SEE THE NETWORK SWIMO-XXXXX ON LIST OF NETWORK, THEN RENEW THE PROCESS TO CONNECT THE CONTROLLER TO THE CLIENT NETWORK.

4 / YOU WANT TO DRIVE YOUR POOL WITH GOOGLE HOME ASSISTANT

GO TO THE [HTTPS://CONSOLE.ACTIONS.GOOGLE.COM/](https://console.actions.google.com/) AND CREATE A NEW PROJECT

THEN FOLLOW OUR API TO DRIVE YOUR POOL WITH YOUR VOICE (SEE NEXT)

YOUR ARE ABLE TO DEPLOY A WONDERFULL PLUG IN FOR THE CLAIRCONNECT SWIMO ,

CALL US +33 68024 6092

2 PLUG IN : LIFE DOMUS AND JEEDOM ARE ON THE WAY ! SOON AVAILABLE

API LOCALE V2

22/08/2018

GET :

PARAM ET OPTION

REGLES /RULES

LINUX APPROACH :

PARAM :

GET

SHOW A GET MUST TO SET
PARAMETER / INDIQUE UN
PARAMETRE OBLIGATOIRE GET

API =<APIKEY>

SERIAL =<N°DE SERIE>

OPTION :

SHOW AN OPTIONAL PARAMETER /
INDIQUE UN PARAMETRE
OPTIONNEL GET

CHEMIN / WAY

[IP/CGI-BIN](#)

METHODE / METHOD

GET ALL

<IPMACHINE>/CGI-BIN/GETALL

IP : IP LOCAL OU IP PUBLIC

GET ALL RENVOIE GLOBALEMENT, LE COMPTE, LES CAPTEURS ET EQUIPEMENTS CONNECTES.

PARAM :

SERIAL= <N° DE SERIE>

API= <APIKEY>

"USER":{

{

"SWIMO":"v.0.11.22",

VERSION DU

CONTROLEUR

"VERSION":"v.0.1.0",

VERSION DE

LA BASE USER

"IPMACHINE":"192.168.0.31",

"TYPEBASSIN":"PISCINE", PISCINE OU SPA / 0 OU 1

"TYPEABRIS": "_INT", // _INT OU _EXT

"UNIT":"METRIC", METRIC OU IMPERIAL

"ACCUEIL_ANALYSE":{

{

"SENSORTYPE":"1", ///VOIR TABLE SENSOR TYPE

"NMSSENSOR":"4", // NMSSENSOR CORRESPOND AU N° SUR CIRCUIT

"CURRENTDATE":"2018-08-08 13:17:17",

"ETATSENSOR":"1", /// SI =1 CAPTEUR EN ERREUR

"NAMESENSOR":"TEMPERATURE", //CHAMPS MODIFIABLE

"MINSENSOR":"26.69", //VALEUR MINIMUM ENREGISTREE DEPUIS MINUIT

"MAXSENSOR":"28.39", //VALEUR MAX ..

"ALARMMIN": "3", ALARME DE DECLENCHEMENT NOTIFICATION

"ALARMMAX": "10", ALARME DE DECLENCHEMENT NOTIFICATION

"LIVESENSOR":[8 DERNIERS RELEVES ESPACES DE 1 MINUTE

"26.73",

"26.73",

"26.73",

"26.71",

"26.71",

"26.69",

"26.78",

"26.75"

],

"UNITCONSIGNE":"°C", // UNITCONSIGNE

"LANG":"FR",

"VOLUME":"40", // VOLUME DU BASSIN

"OFFSETSENSOR": "0", // AJUSTEMENT DU CAPTEUR +
OU -

"TYPECALIBRATION": "0", // 0 A 3 POINTS DE
CALIBRATION

"DATECALIB": "0000-00-00 00:00:00" // DATE DE LA
DERNIERE CALIBRATION

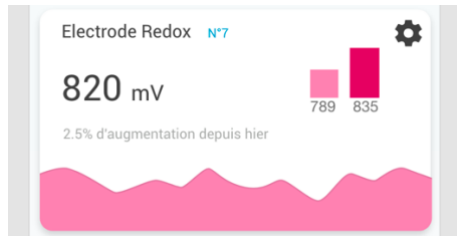

"ACCUEIL_APPAREIL": [

{

"NAMEACTION": "POMPE FILTRATION", // CHAMPS
MODIFIABLE

"IDACTIONTYPE": "1",

"NMACTION": "1", // N° DE PORT SUR CIRCUIT

"TEXTDEVICE": "AUTO", // RENVOIE LE CODE DU
PROGRAMME EN COURS

"CONSIGNE": "20", // RENVOI -1 OU ENSEMBLE VIDE SI
NON UTILISE

"UNITCONSIGNE": "MG/L", // RENVOI -1 OU ENSEMBLE
VIDE SI NON UTILISE

"SOLDENIVEAU": "-1", // RENVOI -1 OU ENSEMBLE VIDE
SI NON UTILISE

"CONSOJOUR": "14:53:24.000", // TEMPS DE
FONCTIONNEMENT FORMATÉ H : M : S

"ISOFF": "1", // ETAT DE L'EQUIPEMENT : 0
=ETEIND, 1=ALLUMÉ

"SECURITE": "1", // 0 1 (ACCEPTÉ PLAGES) 2 (BOUTON
POUSSOIR, NON VISIBLE SUR SERVEUR) 3 (NON VISIBLE
SUR SERVEUR)

"SELECTEDINDEX": "2", // INDEX DE STATEACT OU CODE
MODE (0-1-2)

"STATEACT": ["1V2V3"],

"CODEMODE": ["ONOFFVAUTO"],

"CURRENTDATE": "2018-08-08 13:18:48"

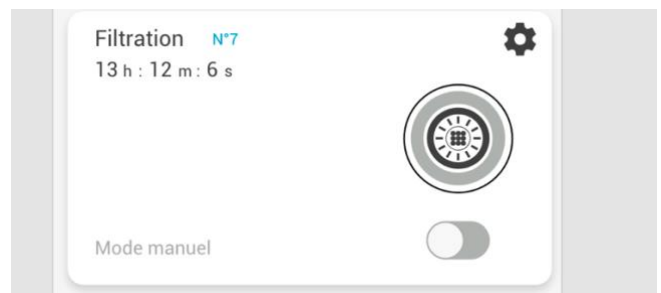
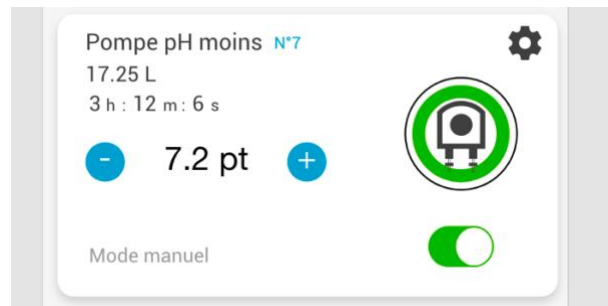

UPDATE SYST

POSSIBILITE DE VALIDER CHAQUE PARAM
INDEPENDEMMENT LES UNS DES AUTRES,

**<IPMACHINE>/CGI-
BIN/UPDATESYST?**

PARAM :

SERIAL= <N° DE SERIE>

API= <APIKEY>

OPTION :

UNIT METRIC, IMPERIAL (°C,
°F)

LANG FR, EN, ES

TYPE 0=PISCINE, 1=SPA

VOL VOLUME EN M3
(STEP=0.1)

ABRIS _INT /_EXT

ANSWER :

TRUE

GET DEVICES

<IPMACHINE>/CGI-BIN/GETDEVICES?NMACTION=5

PARAM :

SERIAL= <N° DE SERIE>

API= <APIKEY>

NMACTION

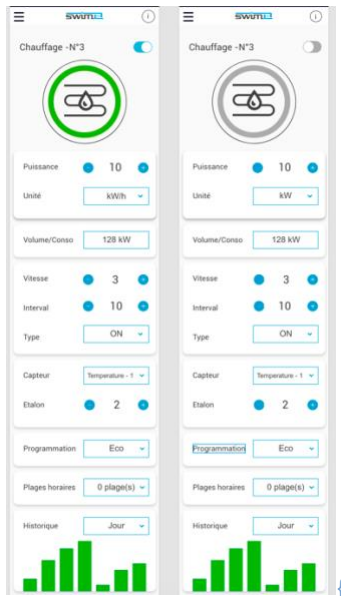

"DEVICES":{

{

"NAMEACTION":"POMPE CHLORE",

"IDACTIONTYPE":"4",

"NUMBER":"2", SEND NUMBER AND NMACTION FOR V1 ET V2

"NMACTION":"2",

"TEXTDEVICE":"ECO", SEND CODE PROGRAM

"ISOFF":"1", 0= SWITCH OFF, 1 SWITCH ON

"SECURITE":"1", 1 ALLOW OVER THE NET, 2 NOT ALLOW OVER THE NET,

"SELECTEDINDEX":"2", 0, 1, 2 (so 0 is ON)

"STATEACT":["1/2/3"], FOR 1/2/3

"CODEMODE":["ON/OFF/AUTO"], FOR ON/OFF/AUTO

"POWER":"20.000000", UPDATE > VAL

"UNITPOWER":"", UPDATE > UNITPOWER

"CONSIGNE":"1.400000", SETPOINT UPDATE > CON

"UNITCONSIGNE":"MG/L",

"NIVEAU":"20", IF -1, NOT USED, VOLUME TANK UPDATE > BID

PROGRAMME

"SELECTEDSEQ":"0", UPDATE > CODESEQ

"STATPROG":["1/2/3"],

"CODEPROG":["ECO/MAX/CHOC "],

"CURRENTDATE":"2018-08-09 18:54:31"

}

],

"PLAGES":[" // TIME SLOTS

{

"ACTION":"5", V1

"NMACTION":"5", V2

"START":"22:00",

"END":"22:15",

"DAYS":"1234567" FROM MONDAY TO SUNDAY

}

UPDATE DEVICE

CGI-
BIN/UPDATEDEVICE?NMACTION=2

PARAM :

SERIAL= <N° DE SERIE>

API= <APIKEY>

NMACTION OU NUMBER

OPTION :

VAL POWER, VALEUR DEBIT
OU PUISSANCE

CON SETPOINT POINT DE
CONSIGNE

SEQ NOT USED ANYMORE
SEQUENCE V1

BID LEVEL CAN / NIVEAU
BIDON

CODESEQ 0, 1, 2 OR 3 -
SELECTED INDEX FOR PROGRAM :
PLAGE/ECO/MAX

INDEX 0,1 OR 2 SELECTED
INDEX FOR STATUS ON/OFF/AUTO

NAME RENAME THE

ANSWER :

TRUE

GET ANALYSE

CGI-
BIN/GETANALYSE?NMSSENSOR=2

PARAM :

SERIAL= <N° DE SERIE>

API= <APIKEY>

NMSSENSOR OU NUMBER

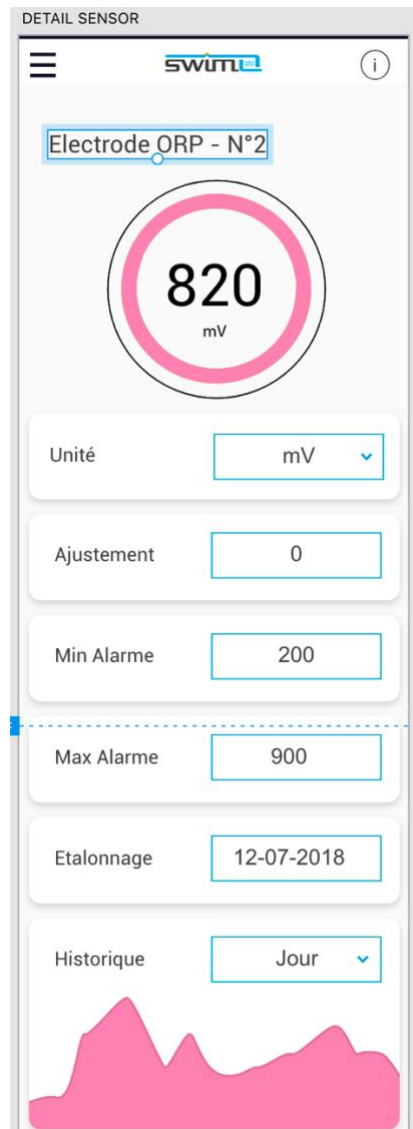

```
"ANALYSE":[  
  
{  
  
"SENSORTYPE":"5", TYPE FROM A LIST (SEE AT THE  
END)  
  
"NUMBER":"2",NUMBER V1 OR  
  
"NMSSENSOR":"2", NMSSENSOR V2  
  
"CURRENTDATE":"2018-08-09 19:14:32", LAST SENT  
  
"ETATSENSOR":"1",  
  
"NAMESENSOR":"ELECTRODE ORP", RENAME >  
UPDATE : NAMESENS
```

```
" ALARMIN":"100", ALARME MIN < SEND A  
NOTIFICATION IS REACHES (VIA SERVER)
```

```
" ALARMMAX":"1000", ALARME MAX > SEND A  
NOTIFICATION IS REACHES (VIA SERVER)
```

```
"LIVESENSOR":"809", THE VALUE LIVE OF TH SENSOR
```

```
"OFFSETSENSOR":"0", UPDATE AN OFFSET > :  
SETSENS
```

```
"UNITCONSIGNE":"MV", UPDATE > UNITCONSIGNE
```

```
"TYPECALIBRATION":"2", HARD > IT IS A VERY CLOSED  
CONTROLLER MANIPULATION
```

```
"DATECALIB":"0000-00-00 00:00:00" LAST  
CALIBRATION DATE
```

```
}
```

DEFAULT HISTORIC 24H -144

```
"HISTORIQUE":[
```

```
{
```

```
"RELEVE":"809", /// VALUE
```

```
"INSERTION":"2018-08-09 19:14:32" /// DATE
```

```
},
```

```
{
```

```
"RELEVE":"813",
```

```
"INSERTION":"2018-08-09 19:09:31"
```

```
},
```

```
{
```

```
"RELEVE":"800",
```

```
"INSERTION":"2018-08-09 19:04:30"
```

UPDATE SENSOR

CGI-
BIN/UPDATESENSOR?NSENSOR=
2

PARAM :

SERIAL= <N° DE SERIE>

API= <APIKEY>

NSENSOR OU NUMBER

OPTION :

SETSENS OFFSETSENSOR
ADJUSTMENT

MIN DEFINE
MINALARM

MAX DEFINE
MAXALARM

NAMESENS RENAME THE
SENSOR

UNITCONSIGNE UNITE DE LA
LISTE

ANSWER :

TRUE

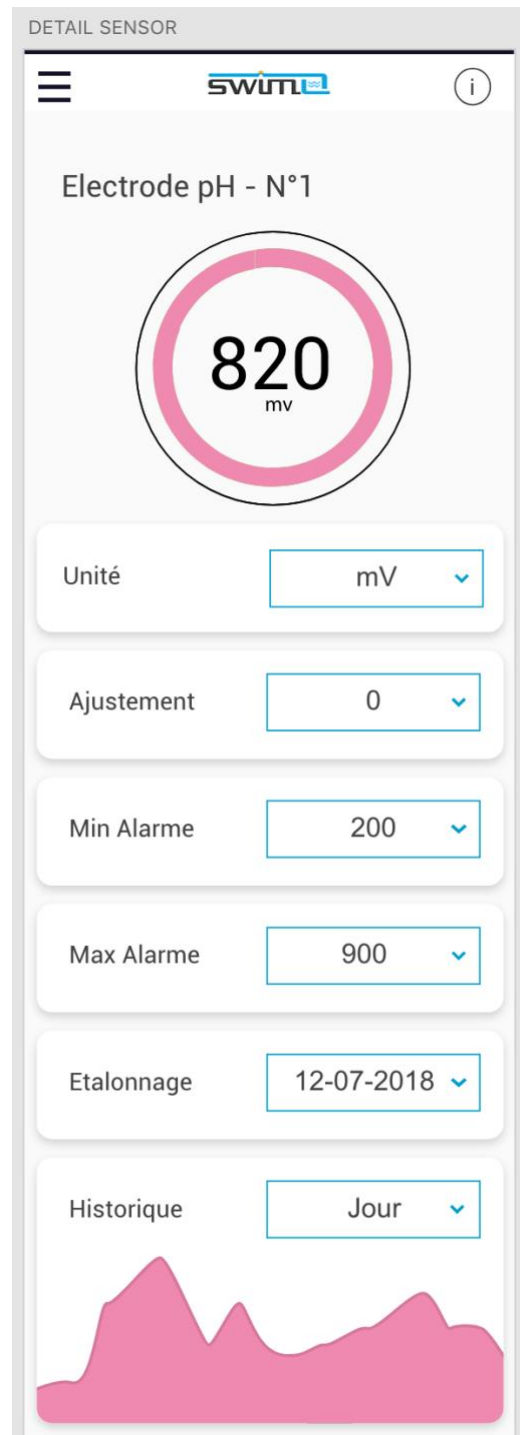

CLAIRCONNECT SWIMO

ADD SENSOR

CGI-BIN/SENSORADD?SENSOR=2&NMSSENSOR=2

PARAM :

SERIAL= <N° DE SERIE>

API= <APIKEY>

NMSSENSOR OU NUMBER (N°SIGNAL)

SENSOR (SENSORTYPE)

@ ADDING A NEW SENSOR

DEL SENSOR

CGI-BIN/SENSORDEL?NMSSENSOR=2

PARAM :

SERIAL= <N° DE SERIE>

API= <APIKEY>

NMSSENSOR OU NUMBER (N°SIGNAL)

@ DELETE A SENSOR

CLAIRCONNECT SWIMO

ADD DEVICE

CGI-BIN/RELAYADD?ACTION=2&NMACTION=2

PARAM :

SERIAL= <N° DE SERIE>

API= <APIKEY>

NMACTION OU NUMBER (N° RELAY)

ACTION (ACTION TYPE)

@ ADDING A NEW EQUIPEMENT

DEL DEVICE

CGI-BIN/RELAYDEL?NMSENSOR=2

PARAM :

SERIAL= <N° DE SERIE>

API= <APIKEY>

NMACTION OU NUMBER (N° RELAY)

@ DELETE AN EQUIPEMENT

CLAIRCONNECT SWIMO

ADD PLAGE

CGI-BIN/PLAGEADD?NMACTION=2&START=08:00&END=12:00&DAYS=123

PARAM :

SERIAL= <N° DE SERIE>

API= <APIKEY>

NMACTION OU NUMBER (N° RELAY)

START (START FORMATED TIME SLOT 08:00)

END (END FORMATED TIME SLOT 16:00)

DAYS (FROM MONDAY TO SUNDAY 1234567)

RETOUR :LISTE DES PLAGES / LIST OF TIME SLOTS

```
"PLAGES":[
{
"ACTION":"5", V1
"NMACTION":"5", V2
"START":"22:00",
"END":"22:15",
"DAYS":"1234567"
```

DEL PLAGE

CGI-BIN/PLAGEDEL?NMACTION=2&START=08:00

PARAM :

SERIAL= <N° DE SERIE>

API= <APIKEY>

NMACTION OU NUMBER (N° RELAY)

START (DEBUT DE PLAGE FORMATEE 08:00) / BEGINING OF FORMATTED TIME SLOT

RETOUR :LISTE DES PLAGES ENCORE ACTIVES / RETURN ACTIVES TIME SLOTS

```
"PLAGES":[
{
"ACTION":"5", V1
"NMACTION":"5", V2
"START":"22:00",
"END":"22:15",
"DAYS":"1234567"
```

CALIBRATION LINUX

MEMO : "TYPECALIBRATION": "2", INDIQUE 2 POINTS DE CALIBRATION

<IPMACHINE>/CGI-BIN/CALIBRATESTART

PARAM :

SERIAL= <N° DE SERIE>

API= <APIKEY>

NUMBER OU NMSSENSOR: N° DE SIGNAL

POINT : N° DU TAMPON

VALUE : VALEUR DE LA SOLUTION TAMPON

DEMARRER AVEC BOUTON START

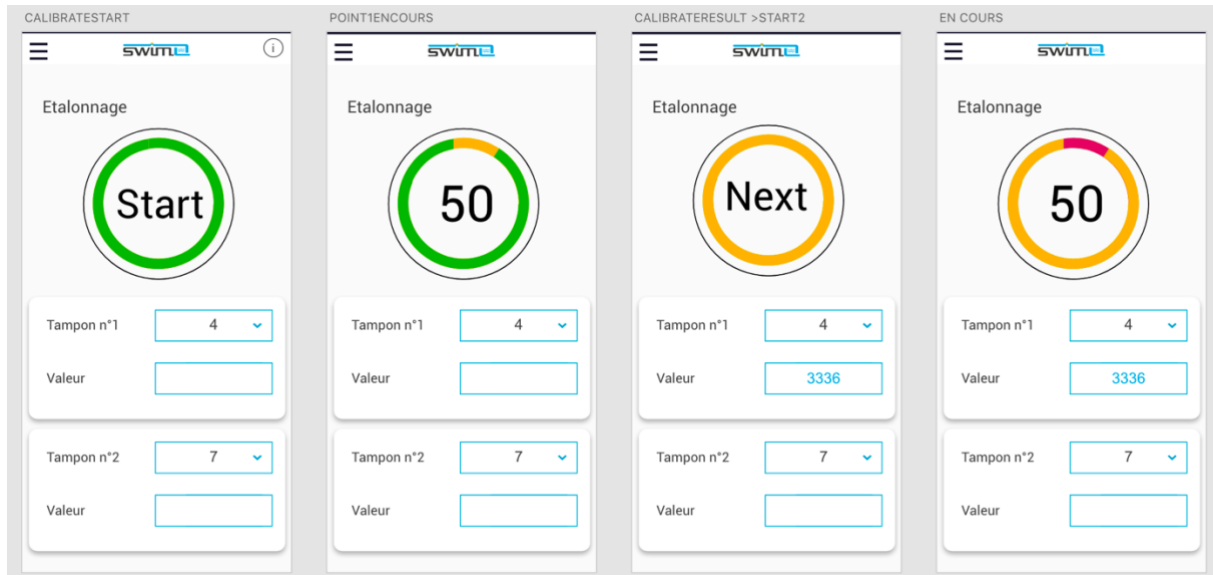

(AU BOUT DE 60 SECONDES, LANCER)

<IPMACHINE>/CGI-BIN/CALIBRATERESULT

PARAM :

SERIAL= <N° DE SERIE>

API= <APIKEY>

NUMBER OU NMSSENSOR: N° DE SIGNAL

POINT : N°DE POINT

ANSWER :

"VALEUR": "3424" OU TRUE

OU

FALSE

RECOMMENCER PROCEDURE SELON NBRE TYPE CALIBRATION, EN AFFICHANT

BOUTON NEXT

FINALISER AVEC BOUTON END

CLAIRCONNECT SWIMO

SETUP WIFI LINUX



IPMACHINE >/CGI-BIN/GETSSID

RENVOIE LA LISTE DES RESEAUX WIFI BRUTE

SET WIFI

HTTP://< IPMACHINE >/CGI-BIN/SETSSID?

PARAM :

SSID= <NOM DU RESEAU>

PASS= <PASSWORD>

SERIAL= <N° DE SERIE>

API= <APIKEY>

RESET WIFI

HTTP://< IPMACHINE >/CGI-BIN/RESETWIFI?

PARAM :

SERIAL= <N° DE SERIE>

API= <APIKEY>

CLAIRCONNECT SWIMO

CLAIRCONNECT SWIMO